

REVISIONS		
REV.	DESCRIPTION	DATE
A	REFERENCE	1/16/2024

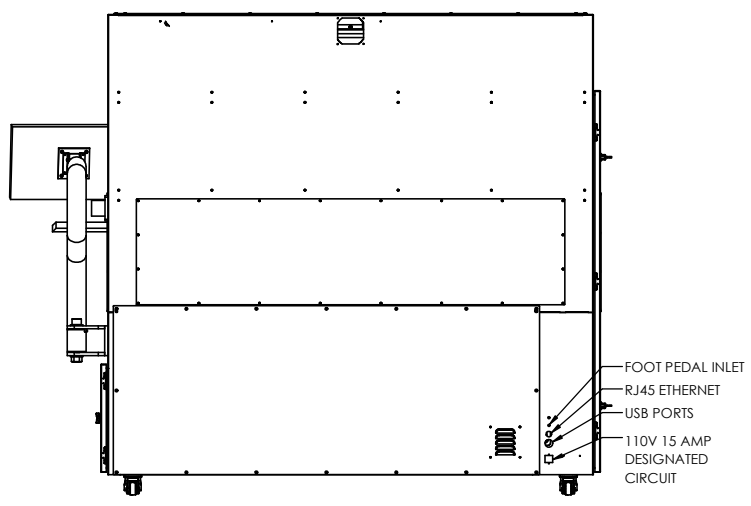
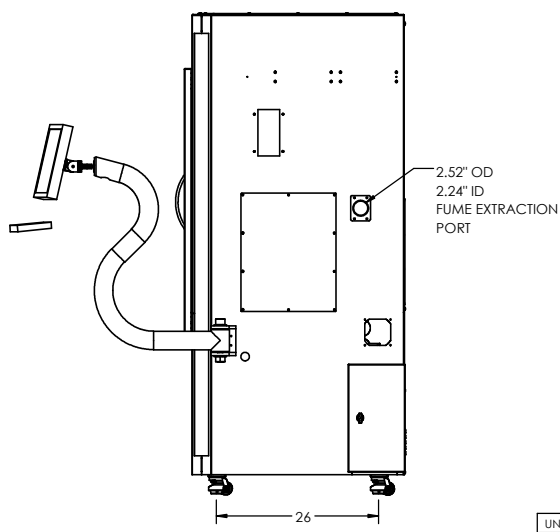
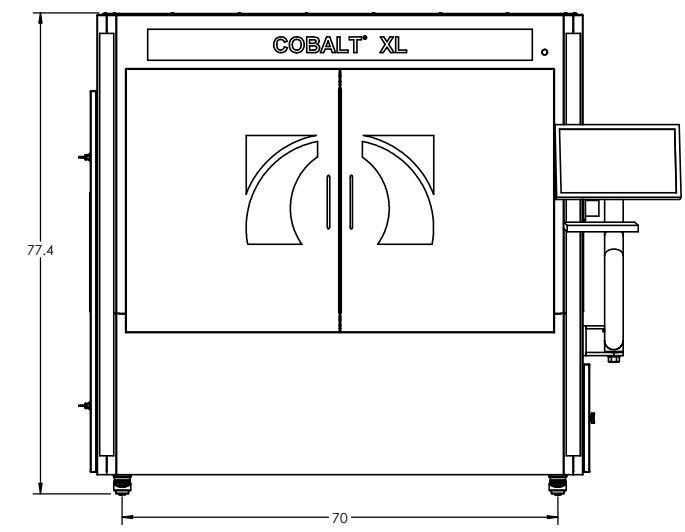
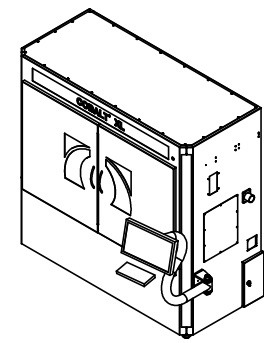

UNLESS OTHERWISE SPECIFIED:
 ALL ALUMINUM WILL BE BLACK ANODIZED
 DIMENSIONS ARE IN INCHES

TOLERANCES:
 TWO PLACE DECIMAL ±0.01
 THREE PLACE DECIMAL ±0.002
 MAX SURFACE FINISH: 125μIN
 DOWEL HOLE TOLERANCES:
 P.F. +0.0000/-0.0005
 S.F. +0.0010/+0.0005

MATERIAL:
 FINISH

DO NOT SCALE DRAWING

	NAME	DATE
DRAWN	CJ	1/16/2024
CHECKED		
ENG APPR.		
MFG APPR.		
Q.A.		
COMMENTS:		

Laser Marking Technologies, LLC

TITLE: COBALT XL PRO
 DESCRIPTION: Standard

SIZE	DWG. NO.	REV
B	LMT-12349	A

SCALE: 1:20 WEIGHT: SHEET 1 OF 1

PROPRIETARY AND CONFIDENTIAL
 THE INFORMATION CONTAINED IN THIS DRAWING IS THE SOLE PROPERTY OF LASER MARKING TECHNOLOGIES, LLC. ANY REPRODUCTION IN PART OR AS A WHOLE WITHOUT THE WRITTEN PERMISSION OF LASER MARKING TECHNOLOGIES, LLC IS PROHIBITED.